

Splice Foot

Rail Shelf

- ▶ Allows for easier rail support
- ▶ Aligns CrossRail T-Bolt channel

Self-Tapping Screws

- ▶ Self-sealing; no sealant required
- ▶ Self-tapping; no pilot holes required
- ▶ 2 screws included per mount

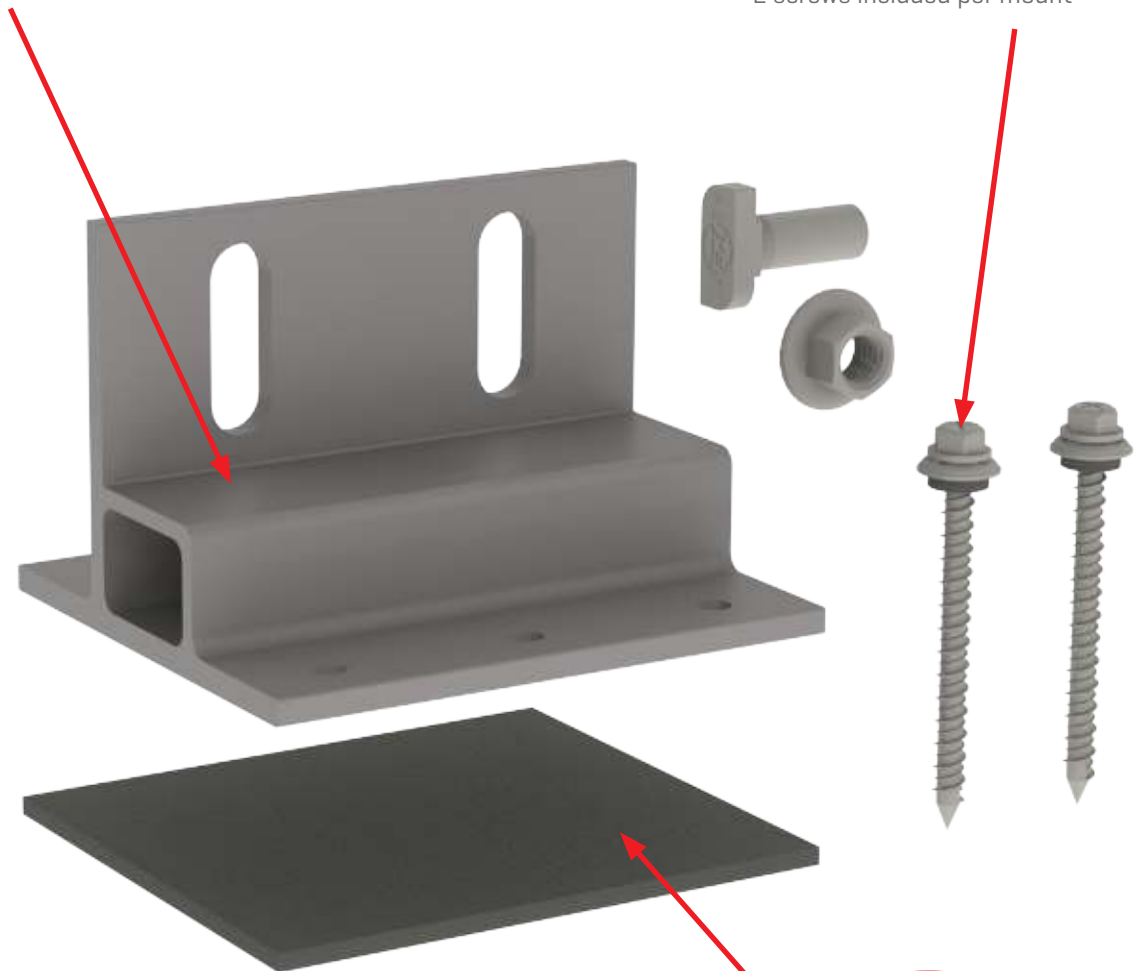

K2 EverSeal

- ▶ Pre-installed butyl flexible flashing
- ▶ 20+ years of proven water sealing technology
- ▶ TAS 100(A) and Wind Driven Rain tested and approved



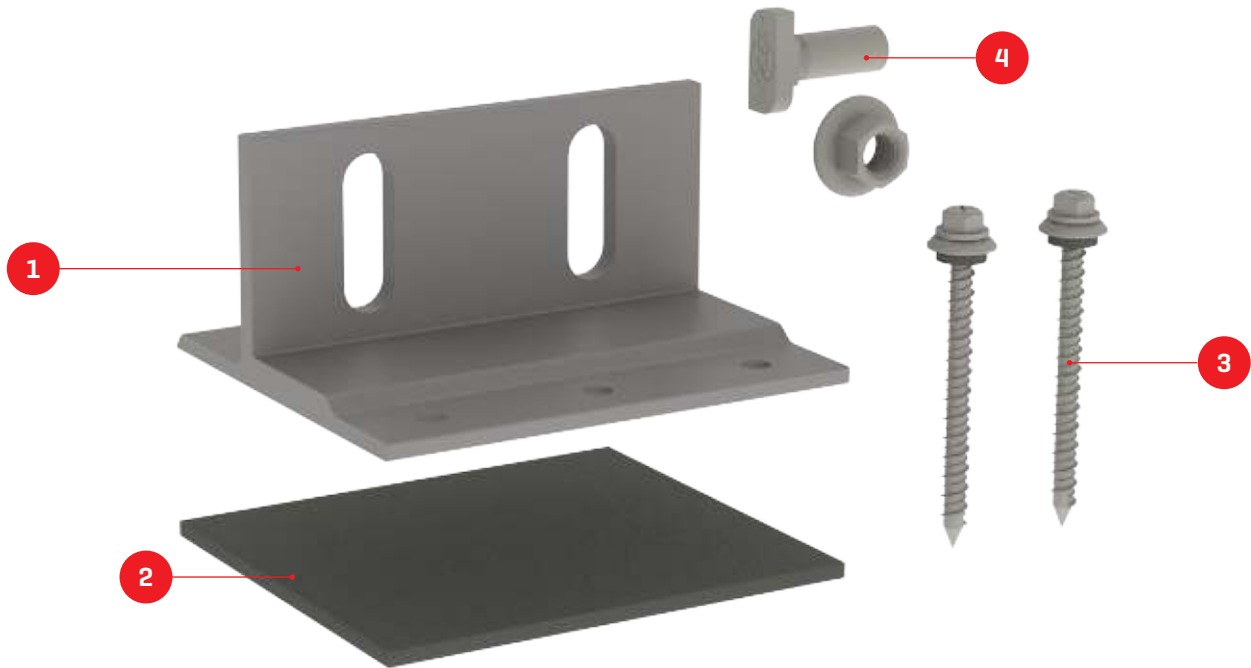

Splice Foot X

Patent Pending

TECHNICAL SHEET

Item Number	Description	Part Number
1	Splice Foot X	4000113 Splice Foot X Kit, Mill
2	K2 EverSeal-	
3	M5 x 60 lag screws	
4	T-Bolt & Hex Nut Set	

Technical Data

	Splice Foot X
Roof Type	Composition shingle
Material	Aluminum with stainless steel hardware
Finish	Mill
Roof Connection	M5 x 60 lag screws
Code Compliance	UL 2703
Compatibility	CrossRail 44-X, 48-X, 48-XL, 80

Units: [in] mm

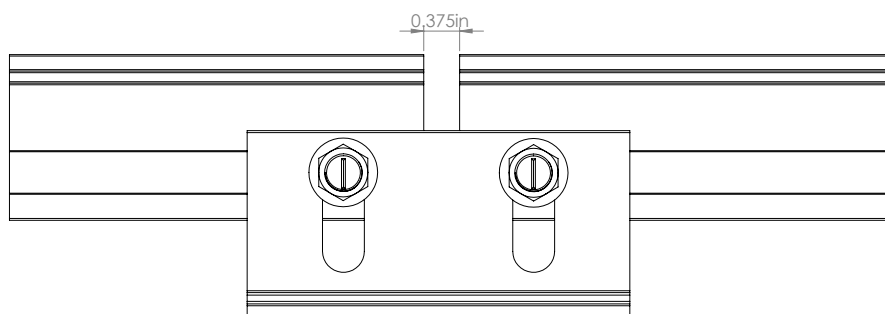
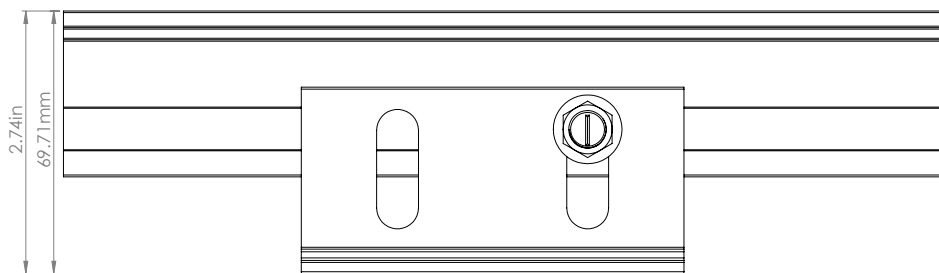
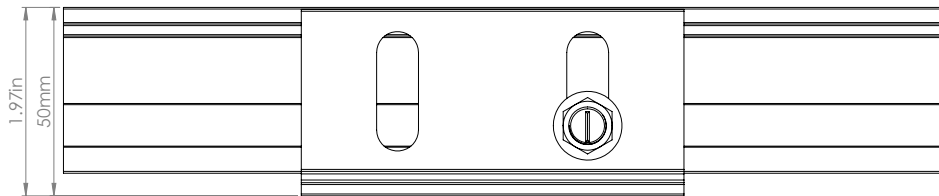
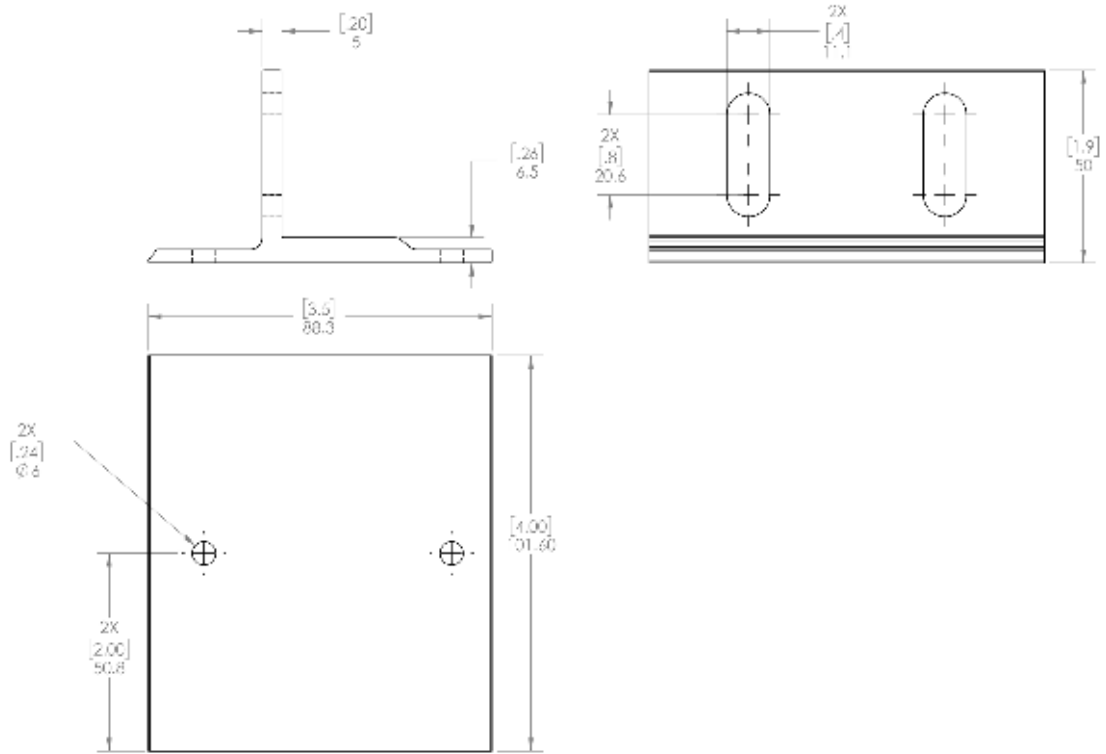



Splice Foot XL

Patent Pending

TECHNICAL SHEET

Item Number	Description	Part Number
1	Splice Foot XL	4000162 Splice Foot XL Kit, Mill
2	K2 EverSeal	
3	M5 x 60 lag screws	
4	T-Bolt & Hex Nut Set	

Technical Data

	Splice Foot XL
Roof Type	Composition shingle
Material	Aluminum with stainless steel hardware
Finish	Mill
Roof Connection	M5 x 60 lag screws
Code Compliance	UL 2703
Compatibility	CrossRail 44-X, 48-X, 48-XL, 80

Units: [in] mm

